



# STANDBY GENERATORS

# 17 kW

## Air-Cooled Gas Engine Generator Sets

### Continuous Standby Power Rating

Model ASPCS1CCA017 (Steel - Gray) - 17 kW 60Hz

Model ASPCA1CCA017 (Aluminum - Gray) - 17 kW 60Hz

### INCLUDES:

- Two Line LCD Digital Controller
- Automatic Transfer Switch with Built-In Priority Load Center
- Electronic Governor
- Pre-wired External Connection Box
- External Main Circuit Breaker, System Status & Maintenance Interval LED's and GFCI Duplex Outlet
- Flexible Fuel Line Connector
- Composite Mounting Pad
- Pre-wired conduits
- Natural Gas or LP Gas Operation
- UL 2200 Listed



## FEATURES

- **INNOVATIVE DESIGN & PROTOTYPE TESTING** are key components of Carrier®'s success in "IMPROVING POWER BY DESIGN." But it doesn't stop there. Total commitment to component testing, reliability testing, environmental testing, destruction and life testing, plus testing to applicable CSA, NEMA, EGSA, and other standards, allows you to choose Carrier® with the confidence that these systems will provide superior performance.
- **IMPROVED ELECTRICAL TECHNOLOGY:** Superior harmonics and sine wave form produce less than 5% Total Harmonic Distortion for utility quality power. This allows confident operation of sensitive electronic equipment and micro-chip based appliances, such as variable speed HVAC.
- **TEST CRITERIA:**
  - ✓ PROTOTYPE TESTED
  - ✓ SYSTEM TORSIONAL TESTED
  - ✓ NEMA MG1-22 EVALUATION
  - ✓ MOTOR STARTING ABILITY
- **SOLID-STATE, FREQUENCY COMPENSATED VOLTAGE REGULATION:** This state-of-the-art power maximizing regulation system is standard on all Carrier® models. It provides optimized FAST RESPONSE to changing load conditions and MAXIMUM MOTOR STARTING CAPABILITY by electronically torque-matching the surge loads to the engine.
- **SINGLE SOURCE SERVICE RESPONSE** from Carrier®'s dealer network provides parts and service know-how for the entire unit, from the engine to the smallest electronic component.
- **CARRIER® TRANSFER SWITCHES:** Long life and reliability are synonymous with Carrier®. One reason for this confidence is that the Carrier® product line includes its own transfer systems and controls for total system compatibility.



# FEATURES

# Carrier® Standby Generator - 17 kW

ENGINE	•Generac (OHVI) Design	Maximizes engine “breathing” for increased fuel efficiency. Plateau honed cylinder walls and plasma moly rings help engine run cooler, reducing oil consumption. Because heat is the primary cause of engine wear, the OHVI has a significantly longer life than competitive engines.
	•”Spiny-lok” cast iron cylinder walls	Rigid construction and added durability provide long engine life.
	•Electronic ignition/spark advance	These features combine to assure smooth, quick starting every time.
	•Full pressure lubrication system	Superior lubrication to all vital bearings means better performance, less maintenance and significantly longer engine life. Now featuring a 2 year/200 hour oil change interval.
	•Low oil pressure shutdown system	Superior shutdown protection prevents catastrophic engine damage due to low oil.
GENERATOR	•High temperature shutdown	Prevents damage due to overheating.
	•Revolving field	Allows for smaller, light weight unit that operates 25% more efficiently than a revolving armature generator.
	•Skewed stator	Produces a smooth output waveform for compatibility with electronic equipment.
	•Displaced phase excitation	Maximizes motor starting capability.
	•Automatic voltage regulation	Regulates the output voltage to ±2% prevents damaging voltage spikes.
TRANSFER SWITCH	•UL 2200 Listed	For your safety
	•Fully Automatic	Transfers your vital electrical loads to the energized source of power.
	•Remote Mounting	Mounts near your existing distribution panel for simple, low cost installation.
CONTROLS	•UL Listed	For your safety
	•Manual/Auto/Off switch	Selects the operating mode.
	•Utility voltage sensing	Constantly monitors utility voltage, setpoints 65% dropout, 75% pick-up, of standard voltage.
	•Utility interrupt delay	Prevents nuisance start-ups of the engine, adjustable 10-30 seconds.
	•Engine warm-up	Ensures engine is ready to assume the load, setpoint approximately 10 seconds.
	•Engine cool-down	Allows engine to cool prior to shutdown, setpoint approximately 1 minute.
	•Seven day exerciser	Operates engine to prevent oil seal drying and damage between power outages.
	•Timed Trickle Battery charger	Maintains battery charge level to insure starting.
	•Main Line Circuit Breaker	Protects generator from overload.
UNIT	•Electronic governor	Maintains constant 60 Hz frequency.
	•Weather protective enclosure	Ensures protection against mother nature. Hinged key locking roof panel for security. Lift-out front for easy access to all routine maintenance items. Electrostatically applied textured epoxy paint for added durability. Aluminum enclosure available as an option.
	•Enclosed critical grade muffler	Quiet, critical grade muffler is mounted inside the unit to prevent injuries.
INSTALLATION SYSTEM	•Small, compact, attractive	Makes for an easy, eye appealing installation.
	•Pre-wired External Connection Box	Easy Installation - Virtually all hardware included, plus step-by-step photographed Installation Guide.
	•1' Flexible Fuel Line Connector	
	•Composite Mounting Pad	
•Pre-wired conduits		
	•UL Listed wire nuts	

# SPECIFICATIONS



GENERATOR		Model ASPCS1CCA017 (17 kW)	Model ASPCA1CCA017 (17 kW)
Rated Maximum Continuous Power Capacity (LP)		17,000 Watts*	17,000 Watts*
Rated Maximum Continuous Power Capacity (NG)		16,000 Watts*	16,000 Watts*
Rated Voltage		120/240	120/240
Rated Maximum Continuous Load Current 240 Volts		70.8 LP/66.6 NG	70.8 LP/66.6 NG
Total Harmonic Distortion		Less than 5%	Less than 5%
Main Line Circuit Breaker		65 Amp	65 Amp
Phase		1	1
Number of Rotor Poles		2	2
Rated AC Frequency		60Hz	60Hz
Power Factor		1	1
Battery Requirement (not included)		Group 26R 12 Volts and 525 Cold-cranking Amperes Minimum	Group 26R 12 Volts and 525 Cold-cranking Amperes Minimum
Unit Weight		455 Pounds	421 Pounds
Dimensions (L" x W" x H")		48 x 25 x 29	48 x 25 x 29
ENGINE		Model ASPCS1CCA017 (17 kW)	Model ASPCA1CCA017 (17 kW)
Type of Engine		GENERAC OHVI V-TWIN	GENERAC OHVI V-TWIN
Number of Cylinders		2	2
Rated Horsepower		32 @ 3,600 rpm	32 @ 3,600 rpm
Displacement		992cc	992cc
Cylinder Block		Aluminum w/Cast Iron Sleeve	Aluminum w/Cast Iron Sleeve
Valve Arrangement		Overhead Valve	Overhead Valve
Ignition System		Solid-state w/Magneto	Solid-state w/Magneto
Governor System		Electronic	Electronic
Compression Ratio		9.5:1	9.5:1
Starter		12 Vdc	12 Vdc
Oil Capacity Including Filter		Approx. 1.7 Qts.	Approx. 1.7 Qts.
Operating RPM		3,600	3,600
Fuel Consumption			
Natural Gas	cu.ft./hr.		
	1/2 Load	183	183
	Full Load	261	261
Liquid Propane	ft <sup>3</sup> /hr (gal/hr)		
	1/2 Load	59 (1.61)	59 (1.61)
	Full Load	94 (2.57)	94 (2.57)
Required fuel pressure to generator fuel inlet at all load ranges - 5 to 7 inches of water column for natural gas, 11 to 14 inches of water column for LP gas			
CONTROLS			
2-Line Plain Text LCD Display		Simple user interface for ease of operation	
Mode Switch			
-Auto		Automatic Start on Utility failure. 7 day exerciser	
-Off		Stops unit. Power is removed. Control and charger still operate.	
-Manual/Test (start)		Start with starter control, unit stays on. If utility fails, transfer to load takes place.	
Engine Start Sequence		Cyclic cranking: 16 sec. on, 7 rest (90 sec. maximum duration)	
Engine Warm-up		10 seconds	
Engine Cool-Down		1 minute	
Starter Lock-out		Starter cannot re-engage until 5 sec. after engine has stopped.	
2.5 Amp Timed Trickle Battery Charger		Standard	
Automatic Voltage Regulator w/Overvoltage Protection		Standard	
Automatic Low Oil Pressure Shutdown		Standard	
Overspeed Shutdown		Standard, 72Hz	
High Temperature Shutdown		Standard	
Overcrank Protection		Standard	
Safety Fuse		Standard	

Rating definitions - Standby: Applicable for supplying emergency power for the duration of the utility power outage. No overload capability is available for this rating. (All ratings in accordance with BS5514, ISO3046 and DIN6271). \* Maximum wattage and current are subject to and limited by such factors as fuel Btu content, ambient temperature, altitude, engine power and condition, etc. Maximum power decreases about 3.5 percent for each 1,000 feet above sea level; and also will decrease about 1 percent for each 12° C (10° F) above 15.5° C (60° F).

# Carrier® Standby Generator - 17 kW

TRANSFER SWITCH & PRIORITY LOAD CENTER	Model ASPCS1CCA017 (17 kW)	Model ASPCA1CCA017 (17 kW)
No. of Poles	2	2
Current Rating (amps)	100	100
Voltage Rating (VAC)	250	250
Utility Voltage Monitor (fixed)		
-Pick-up	75%	75%
-Dropout	65%	65%
Return to Utility	approx. 15 sec.	approx. 15 sec.
Exerciser weekly for 12 minutes	Standard	Standard
UL Listed	Standard	Standard
Dimensions (H" x W" x D")	26.5 x 12.5 x 7	26.5 x 12.5 x 7
Total of Pre-wired Circuits	16	16
No. 15A 120V	5	5
No. 20A 120V	5	5
No. 20A 240V	1	1
No. 40A 240V	1	1
No. 50A 240V	1	1
Circuit Breaker Protected		
Available RMS Symmetrical Fault Current @ 250 Volts	10,000	10,000

## Transfer Switch Features

- Electrically operated, mechanically-held contacts for fast, positive connections.
- Rated for all classes of load, 100% equipment rated, both inductive and resistive.
- 2 pole, 250 VAC contactors.
- 160 millisecond transfer time.
- Dual coil design.
- Main contacts are silver plated or silver alloy to resist welding and sticking.
- NEMA 1 (indoor rated) enclosure is standard on the 100 amp switch.

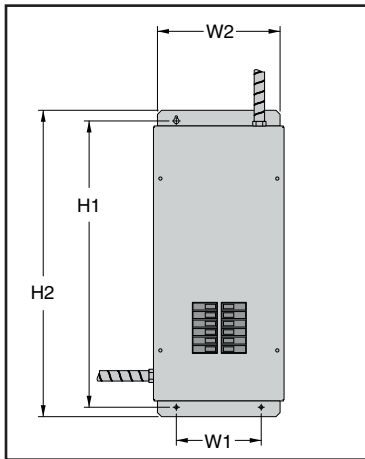

Mechanical Dimensions (in inches)						
Current Rating	No. of Poles	Height		Width		Depth
		H1	H2	W1	W2	
100 UL Listed	2	26.5	29.25	8.14	12.5	7

Terminal Wire Ranges			
ATS Rated Amps	Switch Terminal	Neutral Lug/Stud	Ground Lug
100A 2-Pole UL	1 x 1/0-12	1 x 3/8-16 Stud	1 x 2/0-14

